

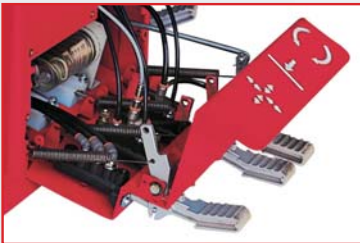

Butler

SEMI-AUTOMATIC TYRE CHANGER

- Heavy duty structure to guarantee proper working conditions at all times.
- Galvanised cylinder with double operation.
- Rigid self-centering chuck and wide clamping range.



Supplied with removable pedal unit for easy maintenance.

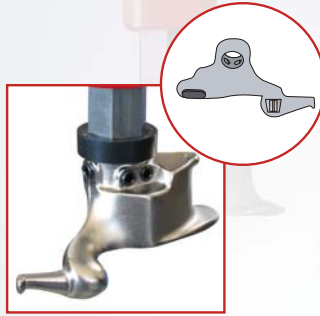

Tool with integrated protection for alloy rims.

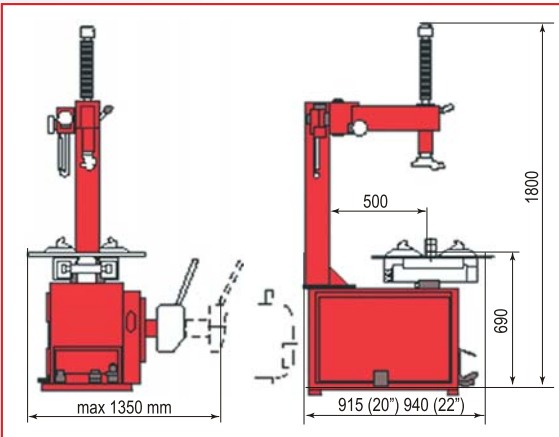

TYRE CHANGERS

TECHNICAL DATA	PC 140.20 PC 140.20FI
Inner clamping	12/22,5
Outer clamping	10"/20"
Max wheel diameter	1030 mm (40,5")
Max wheel width	12"
Bead breaker force	3600 kg (8000 lbs)
Electric motor	0,55 kW
Rotation speed	7,3 rpm
Max torque turntable	1200 Nm (885 Ft/L lbs)

EQUIP MASTERS CORPORATION

B 211, Arjun Centre, Plot No. 231, Govandi Station Road, Govandi East, Mumbai - 400 088.

Tel.: +91-22-2550 3037 / 250 3038 • Email: sales@dentmasterindia.com

Web: www.dentmastersindia.com

